

HydraRester

Hangsell 15mm – 20mm

Scope of Use / Specification Sheet

The Sioux Chief HydraRester (15-20mm) is available in 'A' size and is ideal for general applications. Arresters suitable for washing machines and dishwashers are available in a copper or chrome finish.

Product List		
Order Code	Size	Model
WHX01	A	15mm HydraRester
WHX04	A	15mm Conetite Tee
WHX05	A	20mm Washing Machine/ Dishwasher – Chrome

Application

The HydraRester 'A' size is ideal for installation on supply lines to washing machines, electronic and clockwork garden water timers, dishwashers and all general domestic and commercial appliances likely to cause water hammer.

Materials

Body	Type L Copper
Piston	HHPP
O-Rings	EPDM
End Fittings	DR Lead Free Brass
Thread	BSP

Scope of Use

Materials in contact with water	Copper, EPDM, PP, DR Lead Free Brass
Maximum operating temperature	90°C
Maximum allowable operating pressure	1500kPa



WHX01



WHX04



WHX05

Features and Benefits

- Simple to install
- Maintenance free
- Cost effective
- Seamless shock absorbing chamber
- Suits hot and cold water
- Protects against fixture damage and flooding

Description

When a shuttering fixture closes, a pressure wave begins to move back along the pipe. As it reaches the arrester the force acts against the arrester piston, which, in turn, pushes against a charge of air. The air is then compressed, dissipating the wave energy and nullifying the hammering effects. Water Hammer Arresters do not compensate for loosely fitted pipe work.

The HydraRester is formed from Type L copper tube and is cold rolled and spun closed seamless. The piston carries two EPDM seals and is lubricated with approved 111 Silicone Compound. System surge pressure can be kept below 1000kPa while the arrester can operate at a safe working pressure to 2300kPa. The device is easily installed via the various BSP threaded fittings and can be mounted in any position 90° to the water flow.

HydraRester

Hangsell 15mm – 20mm

Dimensions

Order Code	Length (A)	Diameter (B)	Tee (C)	Thread Size	Weight
WHX01	173	35	–	15	290g
WHX04	188	35	98	15	100g
WHX05	175	33	64	20	340g

Note: All measurements in mm unless otherwise stated.

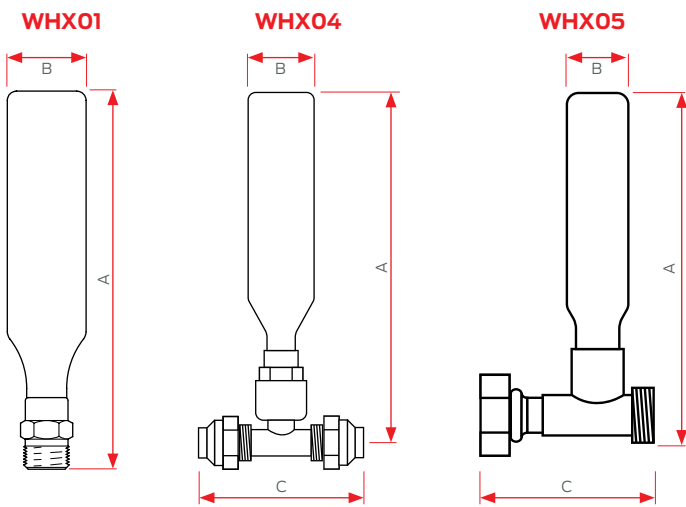

Installation

Installation is subject to the requirements of the applicable regulatory authority, the National Construction Code Volume Three – Plumbing Code of Australia, associated reference standards as applicable at the time and AS/NZS 3500. This product is compliant to the Lead Free requirements of the National Construction Code Volume Three. For further Scope of Use, please visit www.rmc.com.au/resources.

Warranty

Reliance Worldwide Corporation (Aust.) Pty. Ltd. (RWC) will either replace or repair any defective goods where the defect arose as a result of manufacture within the warranty period. You may contact RWC at the phone number, address or e-mail shown below for further information or to make a claim.

Visit www.rmc.com.au/warranty to view the warranty statement in full and for further important information.

Connection

The HydraRester can be easily installed at 90° to the water supply with the choice of fittings eliminating the need for special tools.

All plumbing systems must be structured in accordance with AS/NZS 3500.1 and utilise the correct clipping and supports. Inspect for leaks after installing and before concealing.

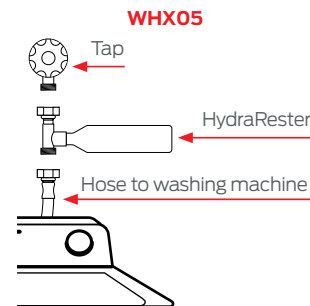
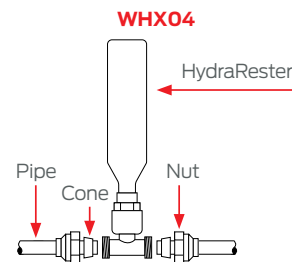
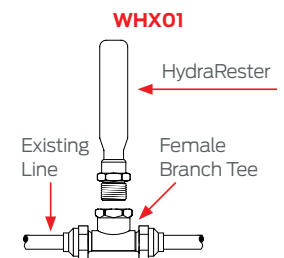

Standards and Approvals



Lead Free

AS 5200.007
WM-020003