

Pressure Reducing Valve

Scope of Use / Specification Sheet

The RMC Commercial PRV is a high flow pressure regulating valve for Commercial and Industrial Installations.

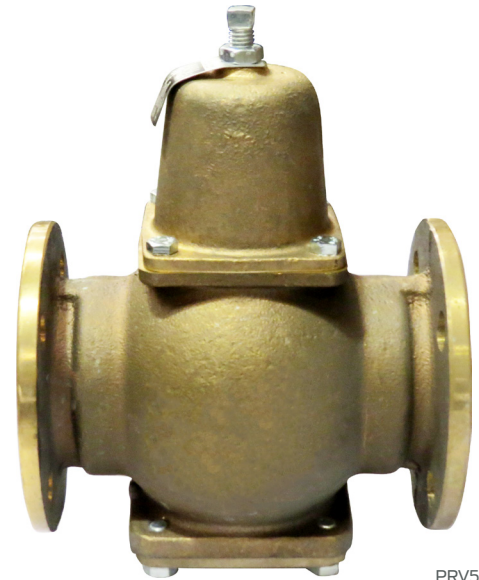

PRV50

Product List

Order Code	Description
PRV50	50mm Flange Commercial PRV
PRV65	65mm Flange Commercial PRV
PRV80	80mm Flange Commercial PRV
PRV100	100mm Flange Commercial PRV
PRV-CSK1	SEAL KIT – Commercial PRV

Materials

Body	Cast Gunmetal
Spring	Spring Steel
Piston	Lead Free Bronze
Body Seat	Lead Free Bronze
Screw/Nut	316 Stainless Steel
Piston	DZR Brass
O-Ring	BUNA-N
Seat Ring	304 Stainless Steel

Application

The high capacity RMC Commercial PRV is ideal for supply to large usage facilities such as factories and industrial establishments. The PRV must be installed in the horizontal position, with the spring chamber upright. For ease of operation and maintenance it is suggested that manual isolation valves be installed upstream and downstream of the valve.

Features and Benefits

- Watermark approved product
- Balanced piston design
- Provides closer regulation and quiet performance
- Every valve is fully factory tested
- Specify and install with confidence
- Simple dependable construction
- Fewer parts for greater reliability
- Flanged connections
- Suitable for all standard installations

Description

The RMC Commercial PRV is supplied standard with flanged connections from 50mm to 100mm diameter. Reliance Commercial PRVs are adjustable from 350kPa – 750kPa, and are factory set at 500kPa.

Pressure Reducing Valve

Technical Specifications

Outlet Pressure Range	350 to 750kPa
Factory Set Pressure	500kPa
Maximum Temperature	60°C
Maximum Operating Pressure	1600kPa

Flow Characteristics

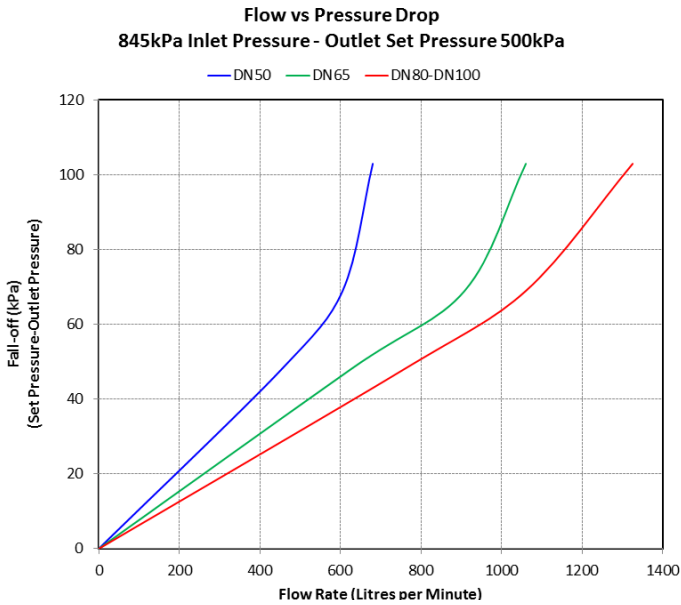

Dimensions

Model	DN	A	B	C
PRV50	50mm Table D	198	190	90
PRV65	65mm Table D	201	190	90
PRV80	80mm Table D	210	190	90
PRV100	100mm Table D	222	190	102

Note: All measurements in mm unless otherwise stated.

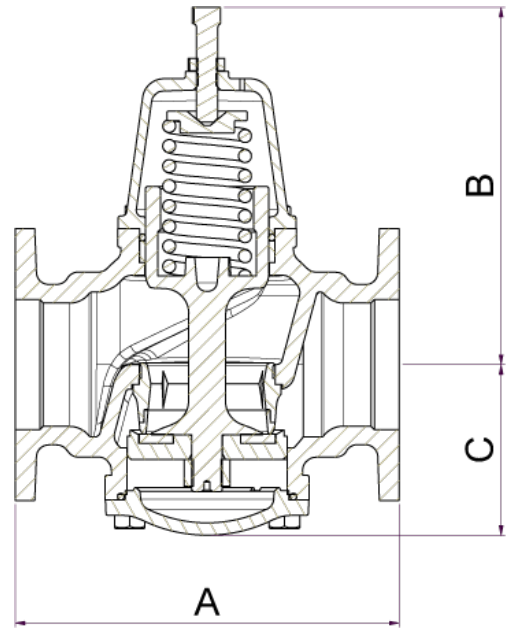

Standards and Approvals



WMTS-052
WMK26247

Warranty

Reliance Worldwide Corporation (Aust.) Pty. Ltd. (RWC) will either replace or repair any defective goods where the defect arose as a result of manufacture within the warranty period. You may contact RWC at the phone number, address or e-mail shown below for further information or to make a claim.

Visit www.rmc.com.au/warranty to view the warranty statement in full and for further important information.