

Combination Non-Return Isolating Valve

Scope of Use / Specification Sheet

The Combination Non-Return Isolating Valve combines the mandatory functions of an isolating valve and non-return valve for the installation of pressurised water heaters.



NI501

NRIS501

Product Code

Model			Product Code
NI50	Duo Valve	15mm F BSP	NI501
NI50-A	Duo Valve	15mm Int Flare	NIA501
NI50-C	Duo Valve*	15mm M Comp	NIC501
NRIS501-S	Trio Valve with Strainer	15mm F BSP	NRIS501

*(Inc. nuts, copper and nylon olives)

Materials

Body	Cast gunmetal
Springs	Stainless steel
O-Rings/Seals	Nitrile
Internal Components	DZR brass/ultem
Strainer	Stainless steel

Description

The RMC Combination Non-Return Isolating Valve provides isolation and prevents the backflow of water from a water heater to the mains line. The device serves the dual purpose of protecting the mains supply from contamination and preventing the loss of water that has already been heated. The isolating valve component is useful as a means of controlling inlet water supply to unvented storage water heaters.

RMC Combination Non-Return Isolating Valve is available in 15mm and 20mm configurations.

Features and Benefits

- Integral construction of non-return valve and isolating valve
- One piece unit for tidy, simple and economical installation
- No intermediate joins or fittings, reducing the opportunity for leaks and faults
- Tamper-proof non-return valve
- NRIS50S 15mm Trio Valve model features integral line strainer for even simpler installation
- Dezincification resistant
- Meets Australian Standard for potable water supply
- Valve designed to work effectively in vertical or horizontal orientation

Application

Combination Non-Return Isolating Valves are suitable for use on water heater systems or wherever both non-return and isolating functions are required. RMC recommends installing a Combination Non-Return Isolating Valve as part of a complete inlet control system for water heater applications.

Installation

Installation is subject to the requirements of the applicable regulatory authority, the National Construction Code Volume Three – Plumbing Code of Australia, associated reference standards as applicable at the time and AS/NZS 3500.1.

Combination Non-Return Isolating Valve

Performance Specifications

Model	Size/Connection	Max. Temperature	Max. Inlet Pressure	Non-Return	Isolating	Line Strainer
NI50	DN15 Female	40°C	1400kPa	✓	✓	
NI50-A	DN15 Internal Flare	40°C	1400kPa	✓	✓	
NI50-C	DN15 Compression	40°C	1400kPa	✓	✓	
NRI50-S	DN15 Female	40°C	1400kPa	✓	✓	✓

Dimensions

Model	Connection (C)	Width (W)	Height (H)
NI50	G½ Female	74	72
NI50-A	DN15Cn INT Flare	86	72
NI50-C	DN15Cn	102	72
NRI50-S	G½ Female	95	83

Note: All measurements in mm unless otherwise stated.

NI50 / NI50-A / NI50-C

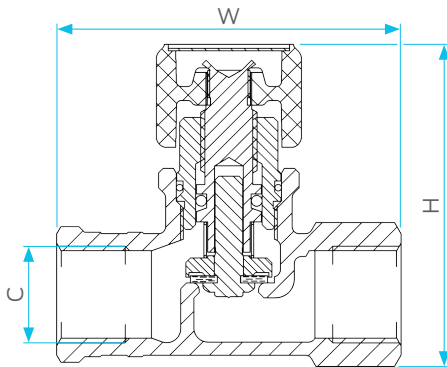

NRI50-S

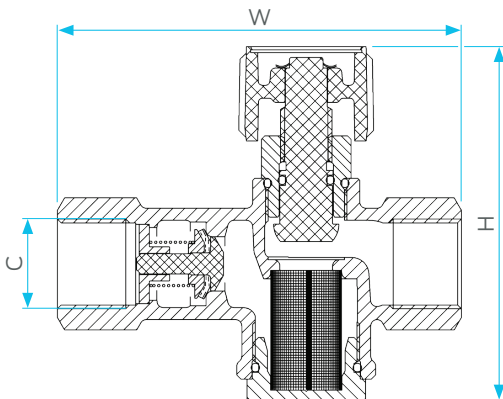

Warranty

Reliance Worldwide Corporation (Aust.) Pty. Ltd. (RWC) will either replace or repair any defective goods where the defect arose as a result of manufacture within the warranty period. You may contact RWC at the phone number, address or e-mail shown below for further information or to make a claim.

Visit www.rmc.com.au/warranty to view the warranty statement in full and for further important information.

Standards and Approvals



AS 1357.1
WMKA21984