

Solar Transfer Valve

Scope of Use / Specification Sheet

The RMC Solar Transfer Valve is used to regulate the flow of water within a solar water heater system with a booster heater.



MIX11091

Product Code

Size	Product Code
20mm (3/4") Male BSP	MIX11091

Materials

Body	Forged Brass
Internal Components	DZR Brass
Seals	Viton®
Springs	Stainless Steel
Piston	Polysulfone
Fittings	DZR Brass
Strainers	Stainless Steel
Non-Return Cartridges	PPO-GF (Noryl®)/EPDM

Description

The RMC Solar Transfer Valve is suitable for domestic applications and has been specially engineered to withstand the extreme thermal demands of solar heating applications. When solar heated water is below a set temperature, the valve will redirect flow to a booster heater. Water that has reached the set temperature will be distributed through the system as normal.

Solar Transfer Valve is available in a 20mm configuration.

Features and Benefits

- High thermal endurance
- Will endure the extreme temperatures present in solar installations
- Ensures that water will always be heated to a minimum temperature
- Integrated non-return valves
- Prevents cross-flow of water through outlet lines
- Union Connections
- Valve easy to install and easy to remove for servicing of strainers
- Strainers upstream of checks
- Protects valve and check valves from impurities in the water supply
- Tamper-proof special adjuster key eliminates chances of accidental adjustment
- Dezincification resistant
- Meets Australian Standard for potable water supply

Application

The RMC Solar Transfer Valve should be installed in solar water heater installations where a booster heater is included to ensure that water is heated to a minimum temperature. The Reliance Solar Transfer Valve redirects water which has not been heated adequately to a booster heater, while allowing water which has reached a set minimum temperature to enter the supply line.

Solar Transfer Valve

Technical Specifications

Transfer temperature range	50°C – 70°C
Hot temperature supply range	60°C – 99°C
Factory set transfer temperature	60°C
Transition zone (where water flows through both outlets)	±3° either side of set transfer temperature
Static supply pressure	1600kPa maximum
Minimum flow rate	4 L/min
Maximum flow rate	43 L/min
Fittings supplied	20mm (3/4") Male BSP Thread

Flow Characteristics

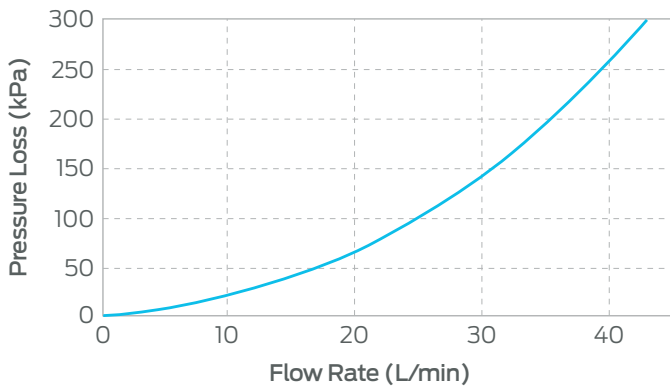

Installation

Installation is subject to the requirements of the applicable regulatory authority, the National Construction Code Volume Three – Plumbing Code of Australia, associated reference standards as applicable at the time and AS/NZS 3500.1.

Standards and Approvals



AS 1357.2
WMKA0938

Dimensions

Size	A	B	C	D	E	F
20mm	118	77	42	53	95	146

Note: All measurements in mm unless otherwise stated.

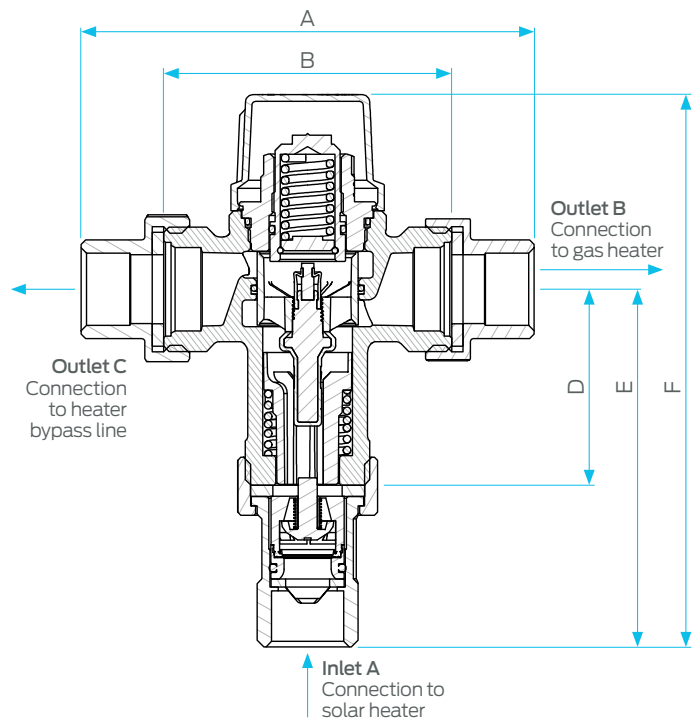

Warranty

Reliance Worldwide Corporation (Aust.) Pty. Ltd. (RWC) will either replace or repair any defective goods where the defect arose as a result of manufacture within the warranty period. You may contact RWC at the phone number, address or e-mail shown below for further information or to make a claim.

Visit www.rmc.com.au/warranty to view the warranty statement in full and for further important information.