

Solar Slick Combo Set

Scope of Use / Specification Sheet

RMC's Solar Slick Combo is a purpose built control valve set, designed to simplify the installation of solar water heaters.

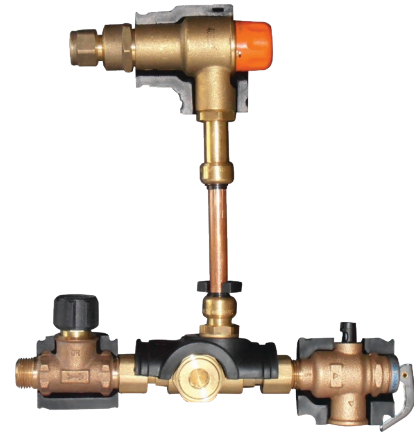

MIX12015I

Product Code

Model	Product Code
Insulated Solar Slick Combo Set	MIX12015I

Materials

Bodies	Forged Brass or Cast Gunmetal
Internal Components	DZR Brass
Internal Seals	Viton® or Nitrile
Springs	Stainless Steel
Tempering Valve Piston	Polysulfone
Fittings	DZR Brass
Circlips	Stainless Steel
Face Seals	EPDM
Check Valve	PPO

Warranty

Reliance Worldwide Corporation (Aust.) Pty. Ltd. (RWC) will either replace or repair any defective goods where the defect arose as a result of manufacture within the warranty period. You may contact RWC at the phone number, address or e-mail shown below for further information or to make a claim.

Visit www.rmc.com.au/warranty to view the warranty statement in full and for further important information.

Installation

Installation is subject to the requirements of the applicable regulatory authority, the National Construction Code Volume Three – Plumbing Code of Australia, associated reference standards as applicable at the time and AS/NZS 3500.1.

Features and Benefits

- All inlet controls in one box
- High thermal endurance
- High-temperature Check Valve
- Protects downstream products from excess supply temperatures
- Fitted Insulation
- Quick, easy and neat mounting for Plumbing Code conformance
- SharkBite® push-to-connect
- Easy alignment and connection of the tempering valve's cold water supply
- High performance tempering valve is individually tested and calibrated
- Integrated strainer protects the system for longer service life
- Dezincification resistant
- Meets Australian Standard for potable water supply
- All components are WaterMarked to their relevant Australian standards

Standards and Approvals

AS 3688
LIC WMKA0158
SAI GLOBAL

AS 3688
LIC WM000979
IAPMO R&T OCEANA

AS 4032.2
LIC WMKA1593
SAI GLOBAL

AS 13571/2
LIC WMKA21984
SAI GLOBAL

AS 13572
LIC WMKA21984
SAI GLOBAL

Solar Slick Combo Set

Description

The Solar Slick Combo includes a high performance tempering valve, high temperature check valve, non-return valve, isolating valve and strainer, plus SharkBite® push-fit for the tempering valve cold water supply connection.

The Solar Slick Combo inlet control valves prevent backflow of water from the water heater to the mains line, protecting the mains supply from contamination and preventing the loss of water that has already been heated. The high performance tempering valve component mixes hot water with cold water to deliver tempered water at a constant temperature throughout the system, and is ideal for use in installations where there are fluctuations in supply conditions. Additionally, a high temperature check valve protects the system from any excess supply temperatures.

Note: Expansion control valve not included.

Performance Specifications

Hot temperature supply range	60°C to 99°C
Cold temperature supply range	5°C to 30°C
Maximum supply pressure	1600kPa
Permitted supply pressure variation	2:1 (max)
Operating temperature range	40°C to 50°C
Factory set temperature range	47.5°C ± 3°C
Minimum temperature differential (between hot supply and outlet temperature)	10°C
Minimum flow rate	4 L/min
Maximum flow rate	40 L/min

Flow Characteristics

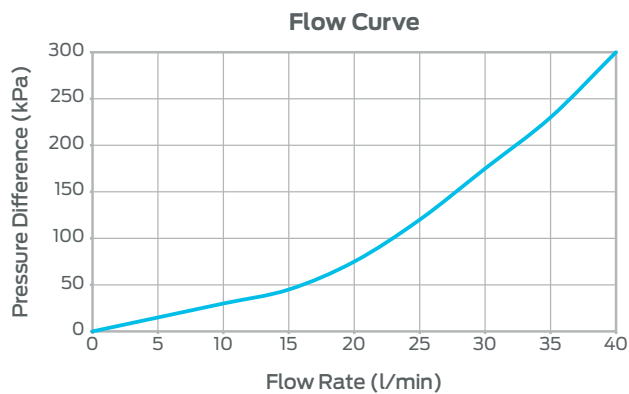

Dimensions

Note: All measurements in mm unless otherwise stated.

Mixing Valve

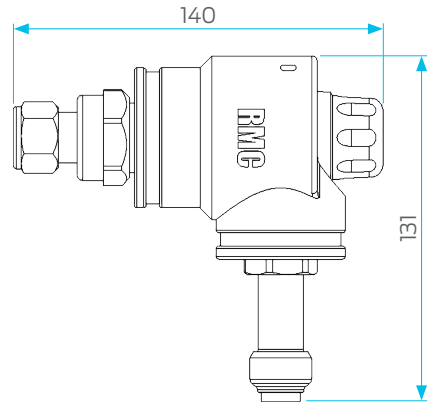

Mixing Valve – Reverse

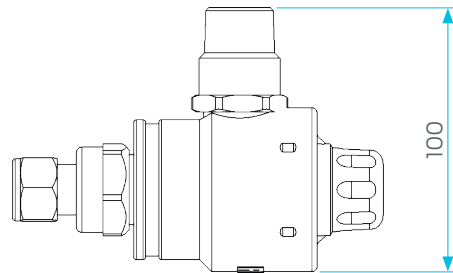

Non-Return Isolating Valve and Manifold

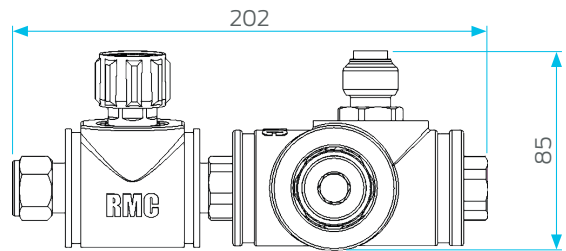

Non-Return Isolating Valve and Manifold – Top

