

Slick Combo Set

Scope of Use / Specification Sheet

RMC's Slick Combo is a purpose built control valve set, designed to simplify the installation of storage water heaters.

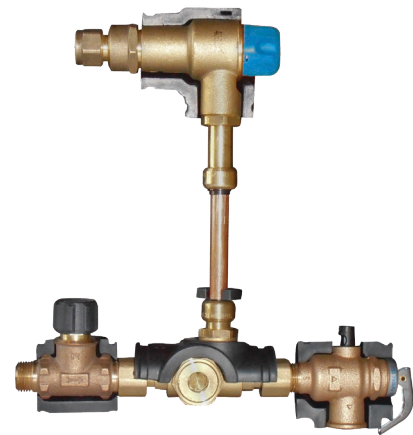

MIX12013I

Product Code

| Model | Product Code |
|---------------------------|--------------|
| Insulated Slick Combo Set | MIX12013I |

Materials

| | |
|------------------------|-------------------------------|
| Bodies | Forged Brass or Cast Gunmetal |
| Internal Components | DZR Brass |
| Internal Seals | Viton® or Nitrile |
| Springs | Stainless Steel |
| Tempering Valve Piston | Polysulfone |
| Fittings | DZR Brass |
| Circlips | Stainless Steel |
| Face Seals | EPDM |

Warranty

Reliance Worldwide Corporation (Aust.) Pty. Ltd. (RWC) will either replace or repair any defective goods where the defect arose as a result of manufacture within the warranty period. You may contact RWC at the phone number, address or e-mail shown below for further information or to make a claim.

Visit www.rmc.com.au/warranty to view the warranty statement in full and for further important information.

Installation

Installation is subject to the requirements of the applicable regulatory authority, the National Construction Code Volume Three – Plumbing Code of Australia, associated reference standards as applicable at the time and AS/NZS 3500.1.

Features and Benefits

- All inlet controls in one box
- Fitted insulation
- Quick, easy and neat mounting for Plumbing Code conformance
- SharkBite® push-to-connect
- Easy alignment and connection of tempering valve cold water supply
- Tempering valve individually tested and calibrated to ensure higher quality and performance
- Integrated strainer protects the system for longer service life
- Dezincification resistant
- Meets Australian Standard for potable water supply
- Suitable for use with either 15mm or 20mm connecting pipework

Standards and Approvals



AS 3688
LIC WMKA0158
SAI GLOBAL



AS 3688
LIC WM000979
IAPMO R&T OCEANA



AS 4032.2
LIC WMKA1593
SAI GLOBAL



AS 1357.1/2
LIC WMKA21984
SAI GLOBAL



AS 1357.2
LIC WMKA21984
SAI GLOBAL

Slick Combo Set

Description

The Slick Combo includes a tempering valve, non-return valve, isolating valve and strainer, plus SharkBite® push-to-connect for the tempering valve cold water supply connection.

The Slick Combo inlet control valves prevent backflow of water from the water heater to the mains line. This protects the mains supply from contamination and the loss of water that has already been heated. The strainer protects the system from any debris and impurities that may be in the water supply. The tempering valve component mixes hot water with cold water to deliver tempered water at a constant temperature throughout the system.

The Slick Combo is supplied with insulation jackets fitted for each valve.

Note: Expansion control valve not included.

Technical Specifications

| | |
|--|--|
| Hot temperature supply range | 60°C to 90°C |
| Cold temperature supply range | 5°C to 30°C |
| Maximum supply pressure | 1600kPa |
| Permitted supply pressure variation | 2:1 (maximum) |
| Operating temperature range | 40°C to 50°C |
| Factory set temperature range | Must be commissioned on site to achieve desired outlet temperature |
| Minimum temperature differential (between hot supply and outlet temperature) | 15°C |
| Minimum flow rate | 4 L/min |
| Maximum flow rate | 50 L/min |

Flow Characteristics

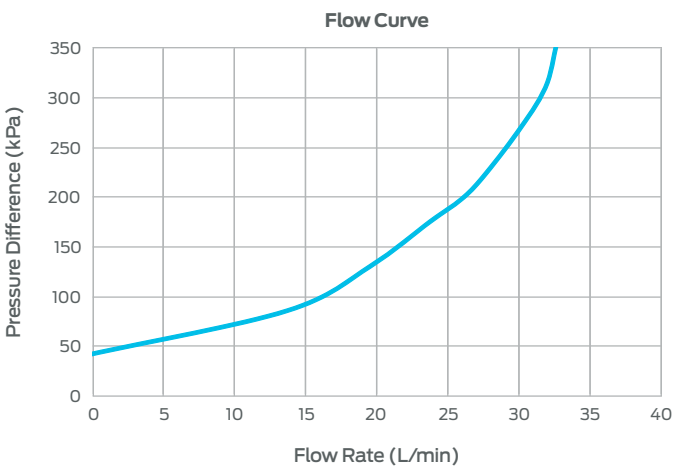

Dimensions

Note: All measurements in mm unless otherwise stated.

Mixing Valve

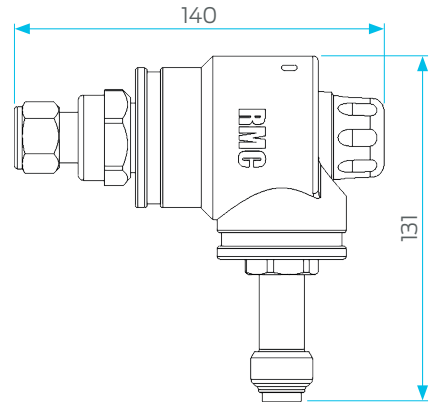

Mixing Valve – Reverse

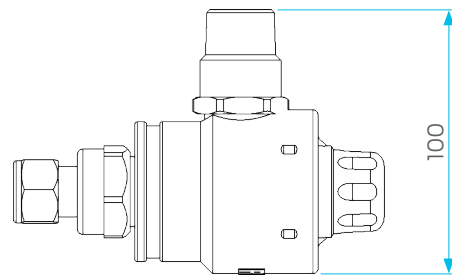

Non-Return Isolating Valve and Manifold

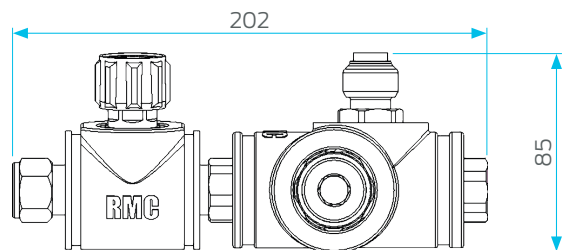

Non-Return Isolating Valve and Manifold – Top

