

# Primary Temperature Control Valve

## Scope of Use / Specification Sheet

RMC's Primary Temperature Control Valve is a temperature control valve that mixes hot water with cold water to deliver blended water at a constant temperature throughout an entire house, building or system.



MIX11092

### Product Code

Size	Product Code
20mm	MIX11092

### Materials

Body	Forged Brass
Internal Components	DZR Brass
Seals	Viton®
Springs	Stainless Steel
Piston	Polysulfone
Fittings	DZR Brass
Strainers	Stainless Steel
Non-Return Cartridges	PPO-GF (Noryl®)/EPDM

### Description

RMC's Primary Temperature Control Valve (PTCV) is suitable for domestic and commercial applications requiring controlled delivery of water heated above temperatures suitable for sanitary devices intended for personal hygiene. PTCV is compatible with both storage, instantaneous and heat exchange (continuous flow) type water heaters, boilers and solar systems.

### Installation

Installation is subject to the requirements of the applicable regulatory authority, the National Construction Code Volume Three – Plumbing Code of Australia, associated reference standards as applicable at the time and AS/NZS 3500.1.

### Features and Benefits

- Mixes hot and cold water to deliver blended water
- Ideal for industrial and commercial applications
- More accurately controls the maximum temperature of delivered water
- Can be installed on water heater systems to prevent superheated water being delivered
- Valve is safer, and easier to install or remove for servicing of strainers upstream of check valves
- Tamper-proof adjustment with special adjuster key eliminates chances of accidental adjustment
- Dezincification resistant
- Meets Australian Standard for potable water supply
- Every valve is individually tested and calibrated to ensure higher quality and performance
- Protects valve from impurities in the water supply

### Application

RMC's PTCV is a temperature control valve for use in hot water distribution systems where temperature control is needed at temperatures higher than those suitable for sanitary devices intended for personal hygiene. Fitting the valve at the hot water source ensures the delivery of constant temperature hot water throughout the system, whilst preventing delivery of superheated water.

RMC's PTCV is NOT INTENDED FOR USE as a tempering valve under any circumstances.

# Primary Temperature Control Valve

## Working Pressures and Temperatures

Cold water supply temperature	5°C – 30°C
Hot water supply temperature	60°C – 99°C
Optimum outlet temperature range	50°C – 70°C
Set temperature	Factory set to 63°C
Accuracy of outlet temperature	±3°C
Minimum temperature differential (between hot supply and outlet temperature)	15°C
Static supply pressure	200 kPa - 1600 kPa maximum <sup>1</sup>
Dynamic supply pressure imbalance (at time of commissioning)	2:1 maximum <sup>2</sup>
Maximum permitted pressure variation in either supply, in order to control outlet temperature to ±3°C (from supply pressure at commissioning)	±10% maximum <sup>3,4</sup>
Minimum flow rate	4 L/min
Maximum flow rate	33 L/min
Fittings supplied	Male BSP Thread

## Notes

- 1 The maximum permitted ratio of supply pressures, under dynamic (flow) conditions. For optimum performance it is recommended that the hot and cold pressures at commissioning are as close as possible to equal.
- 2 The maximum permitted variation in either supply pressure from the pressure at commissioning in order to control the outlet temperature to ±3°C
- 3 Note that rapid changes in supply pressure can result in a spike in the outlet temperature beyond ±3°C. Following a rapid change in supply pressure it may take a number of seconds for the temperature to return to within a ±3°C limit. Steps should be taken on-site to eliminate any cause of rapid supply pressure variation.
- 4 Under flow conditions dynamic pressure should exceed 100kPa.

## Standards and Approvals



AS 1357.2  
WMKA0938

## Dimensions

Model	A	B	C	D	E	F
PTCV	163	77	41	52	73	126

Note: All measurements in mm unless otherwise stated.

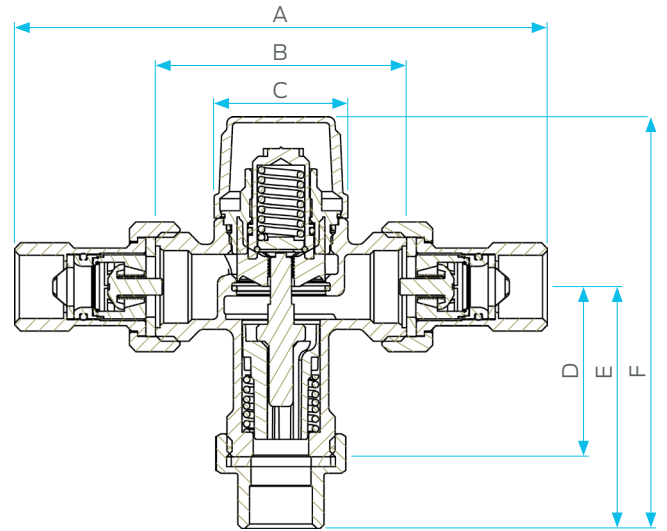

## Flow Characteristics

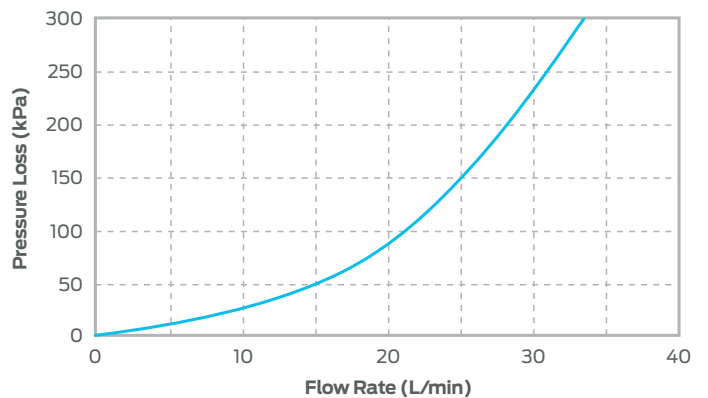

## Warranty

Reliance Worldwide Corporation (Aust.) Pty. Ltd. (RWC) will either replace or repair any defective goods where the defect arose as a result of manufacture within the warranty period. You may contact RWC at the phone number, address or e-mail shown below for further information or to make a claim.

Visit [www.rmc.com.au/warranty](http://www.rmc.com.au/warranty) to view the warranty statement in full and for further important information.