

# Meter Dirt Boxes

## Scope of Use / Specification Sheet

RMC's Meter Dirt Boxes protect downstream lines from congestion from dirt and debris. Large suspended particles and fibrous contamination in the water can impact the measuring characteristics of Woltman Meters and can deposit in the bearings. The dirt filter can guard against particles as small as 5mm from the water and reliably protect the meters that are downstream.

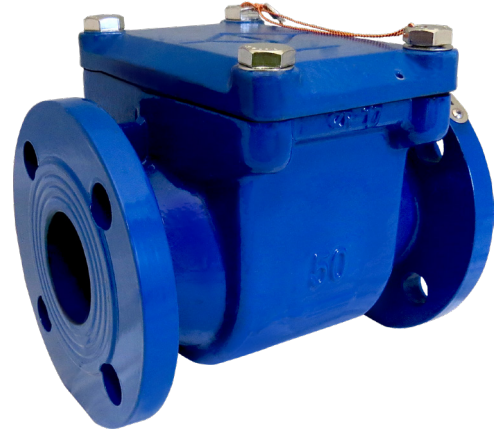

1N114

### Product Code

Model	Length	Catalogue Number
50mm	200mm	1N114
80mm	225mm	1N111
100mm	250mm	1N112
150mm	300mm	1N113

### Features and Benefits

- No contamination of the piping by particles
- Additional protection for a following water meter
- Easy to maintain through removable insert
- Operating pressure 1600kPa
- Application for cold water up to 50°C
- Stainless Steel strainer

### Flow Characteristics

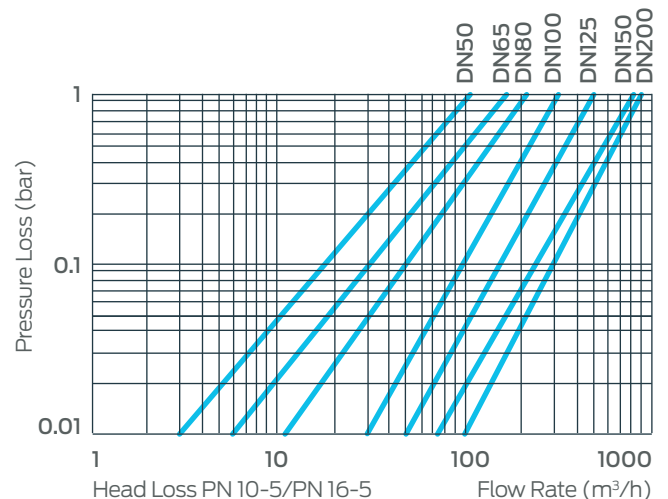

# Meter Dirt Boxes

Dimensions					
Nominal diameter	DN	50	80	100	150
Overall length	L	200	225	250	300
Height	H	176	224	234	277
Flange diameter	D	165	200	220	285
Bolt circle diameter	D1	125	160	180	240
Number of bolts		4	4	4	8
Bolt diameter		19	19	19	23
Weight		12kg	15kg	17kg	35kg

Note: All measurements in mm unless otherwise stated.

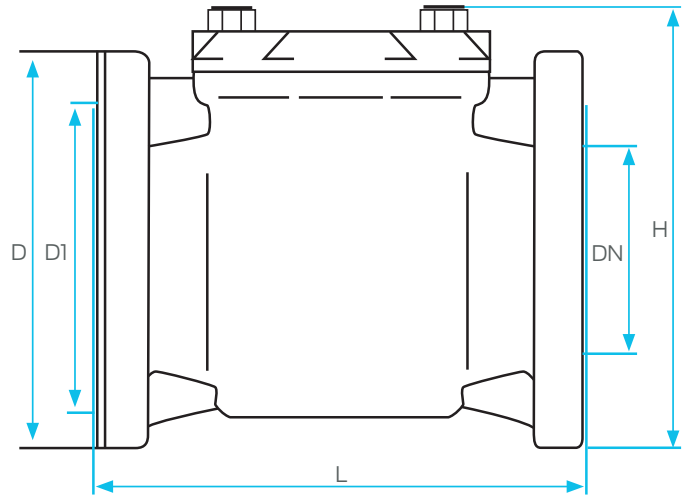

## Standards and Approvals

- Approved utility use only. No WaterMark.

## Warranty

Reliance Worldwide Corporation (Aust.) Pty. Ltd. (RWC) will either replace or repair any defective goods where the defect arose as a result of manufacture within the warranty period. You may contact RWC at the phone number, address or e-mail shown below for further information or to make a claim.

Visit [www.rmc.com.au/warranty](http://www.rmc.com.au/warranty) to view the warranty statement in full and for further important information.

## Installation

Installation is subject to the requirements of the applicable regulatory authority, the National Construction Code Volume Three – Plumbing Code of Australia, associated reference standards as applicable at the time and AS/NZS 3500.1.