

Compact Pressure Reducing Valve

Scope of Use / Specification Sheet

The RMC PressureGuard® Compact Pressure Reducing Valve is used in water systems to limit the downstream pressure to the preset maximum. Easy serviceability and robust design makes the PressureGuard® a premium valve on the market.



PRV15, PRV20, PRV25

Product Code

Model	Product Code
15mm	PRV15
20mm	PRV20
25mm	PRV25

Materials

Body	Forged brass
Spring chamber	Epoxy coated zinc alloy
Adjusting screw	Brass
Pressure plate	Steel (zinc plated)
Diaphragm	EPDM
Seat Disc	EPDM
Piston	DZR brass
Strainer	Stainless steel
O-Ring	EPDM
Cartridge case	mPPE (polyphenylene ether)

Application

The RMC PressureGuard® Compact Pressure Reducing Valve is suitable for use in residential and multilevel installations. The valve maintains a constant maximum outlet pressure to protect downstream installations from variations in supply pressure. Installing a Pressure Reducing Valve can minimise water wastage.

Incorporating the latest technologies into the modular designed compact PRV, the valve is suited for installations in areas with limited access.



Features and Benefits

- Adjustable outlet pressure set
- High flow capacity with minimal head loss
- Suitable for entire residential installations
- Robust design and construction
- Protects downstream installations from excess supply pressure
- Reduces maintenance and repair costs on expensive equipment
- Compact cartridge based design
- Valve and strainer can be serviced without disassembly
- No special tools required for maintenance or adjustment
- Simple screw adjustment mechanism
- Can be installed in any orientation

Technical Specifications

Recommended Operating Pressure Range	500 – 1600kPa
Multiple Installation Operating Pressure Range	500 – 1000kPa
Maximum Inlet Pressure	2000kPa
Maximum Supply Temperature	80°C
Adjustable Outlet Pressure Range	150 – 600kPa
Factory Set Pressure	500kPa ± 10%
Fluid Media	Water

Standards and Approvals



AS 1357.2
WMKA0938
SAI GLOBAL

Compact Pressure Reducing Valve

Dimensions

Model	A	B	C	D	E	F	G
PRV 15mm Female	43	80	94	76	80	RP½	G¼
PRV 20mm Female	43	77	93	76	79	RP¾	G¼
PRV 25mm Female	43	74	93	79	81	RP1	G¼

Note: All measurements in mm unless otherwise stated.

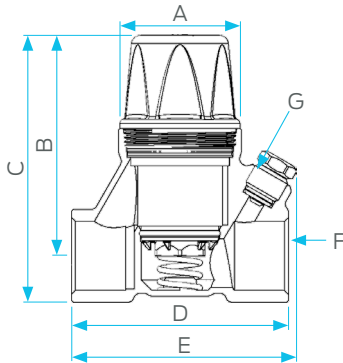

Multi-Storey Buildings

Where multiple pressure reducing valves will be used as part of a hydraulic circuit, consideration should be given to the design of the hydraulic circuit to avoid the operating condition where combined high inlet pressure/low outlet flow-rate results in high water velocity within the pressure reducing valve. Where inlet pressures are likely to exceed 1000kPa, this may be achieved through staged pressure reduction measures.

Installation

Installation is subject to the requirements of the applicable regulatory authority, the National Construction Code Volume Three – Plumbing Code of Australia, associated reference standards as applicable at the time and AS/NZS 3500.1.

- If installing in-ground, valve must be protected by an approved box (should not be buried)
- Avoid the use of garden fertiliser around the installation

Warranty

Reliance Worldwide Corporation (Aust.) Pty. Ltd. (RWC) will either replace or repair any defective goods where the defect arose as a result of manufacture within the warranty period. You may contact RWC at the phone number, address or e-mail shown below for further information or to make a claim.

Visit www.rmc.com.au/warranty to view the warranty statement in full and for further important information.

Flow Rates

DN15	18L/min	150kPa
	60L/min	600kPa
DN20	20L/min	150kPa
	110L/min	600kPa
DN25	35L/min	150kPa
	120L/min	600kPa

