

Tapping Bands

Scope of Use/Specification Sheet

The RMC Tapping Band Range delivers proven performance in a proven design. The range comes in sizes from 40 to 600mm, with take-offs from 20 to 50mm.

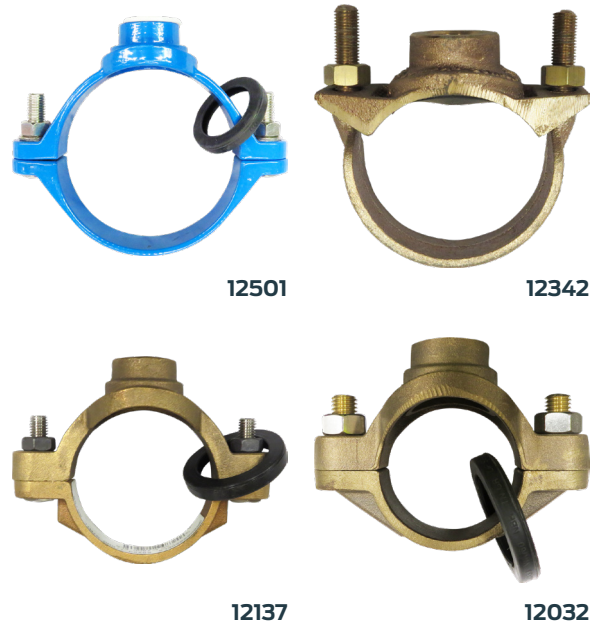

Coated Tapping Saddles for DI and CI Pipe	
Model	Catalogue Number
100mm x 20mm	12501 **
100mm x 25mm	12502 **
150mm x 20mm	12506 **
150mm x 25mm	12507 **

Tapping Saddles – Maintenance Type	
Model	Catalogue Number
80mm x 25mm	12342+
100mm x 20mm	12351+
100mm x 25mm	12352+
100mm x 50mm	12355+
150mm x 20mm	12371+
150mm x 25mm	12372+
150mm x 50mm	12375 *+
225mm x 25mm	12392+
225mm x 50mm	12395 *+
300mm x 25mm	12397+
300mm x 50mm	12400 *+

Installation

Installation is subject to the requirements of the applicable regulatory authority, the National Construction Code Volume Three – Plumbing Code of Australia, associated reference standards as applicable at the time and AS/NZS 3500.1.

Features and Benefits

- Quality guaranteed Standards Marked product
- Standards marked - AS/NZS 4793
- Lip type seal AS 1646
- Cast DR Gunmetal body
- Stainless Steel (316) bolts
- Maximum operating pressure 1.9 MPa
- Ease of installation and reduced leakage due to its patented lip seal
- Long life performance, through its high quality components
- Light weight construction for ease of handling
- Type F Series 1
- Type R
- Coated

Notes

- Maintenance Types are excluded from the current standard For use on AC or oversized AC pipe
- Product material configuration may vary over size range
- Items marked with '*' indicate reducing bushes are to be used to accommodate smaller off-takes
- Items marked with '**' indicate standard with s/s bolts
- Items marked with '+' indicates approved utility use only. No WaterMark
- Insulation may be required for Bi-Metallic contact



Tapping Bands

Tapping Saddles for AC and Compatible Pipe – Series 2

Model	Catalogue Number
58mm x 20mm	12137 **
58mm x 25mm	12138 **
80mm x 20mm	12141 **
80mm x 25mm	12142 **
80mm x 50mm	12145 **
100mm x 20mm	12151 **
100mm x 25mm	12152 **
100mm x 32mm	12153 **
100mm x 40mm	12154 **
100mm x 50mm	12155 **
150mm x 20mm	12171 **
150mm x 25mm	12172 **
150mm x 32mm	12173 **
150mm x 40mm	12174 **
150mm x 50mm	12175 **
200mm x 20mm	12181 **
200mm x 25mm	12182 **
200mm x 50mm	12185 **
225mm x 20mm	12191
225mm x 25mm	12192
225mm x 50mm	12195
250mm x 20mm	12201
250mm x 25mm	12202
250mm x 50mm	12205
300CD x 20mm	12221
300CD x 25mm	12222
300CD x 50mm	12225
375mm x 20mm	12231+
375mm x 25mm	12232+
375mm x 50mm	12235+
450mm x 50mm	12245+
500mm x 50mm	12255+
600mm x 50mm	12275+

Standards and Approvals



WMK025661
AS/NZS 4793

Note: Items marked with a '+' are for approved utility use only. No WaterMark.

Tapping Saddles – White PVC Series 1

Model	Catalogue Number
50mm x 25mm	12012 **
63mm x 20mm Poly	12014 **
63mm x 25mm Poly	12015 **
80mm x 20mm	12031 **
80mm x 25mm	12032 **
80mm x 40mm	12034 **
80mm x 50mm	12035 **
100mm x 20mm	12041 **
100mm x 25mm	12042 **
100mm x 32mm	12043 **
100mm x 40mm	12044 **
100mm x 50mm	12045 **
150mm x 20mm	12061 **
150mm x 25mm	12062 **
150mm x 32mm	12063 **
150mm x 40mm	12064 **
150mm x 50mm	12065 **
200mm x 20mm	12086
200mm x 25mm	12087
200mm x 40mm	12089
200mm x 50mm	12090 *
225mm x 20mm	12091
225mm x 25mm	12092
250mm x 20mm	12101
250mm x 25mm	12102
250mm x 50mm	12105 *
300mm x 20mm	12121
300mm x 25mm	12122
300mm x 50mm	12125 *

Warranty

Reliance Worldwide Corporation (Aust.) Pty. Ltd. (RWC) will either replace or repair any defective goods where the defect arose as a result of manufacture within the warranty period. You may contact RWC at the phone number, address or e-mail shown below for further information or to make a claim.

Visit www.rmc.com.au/warranty to view the warranty statement in full and for further important information.

Tapping Bands

Installation Instructions

RMC Tapping Bands are available for Type F Series 1 pipe, up to size DN300 and Type R AC pipe, up to size DN600.

1. Undo and remove retaining nuts.

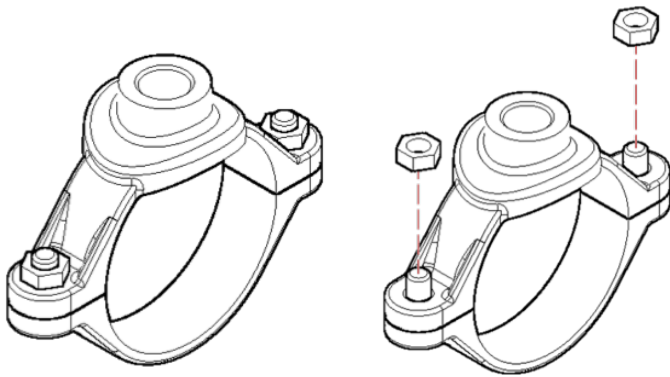

2. Remove top half and seal. Bolts are retained in bottom half by locating seals.

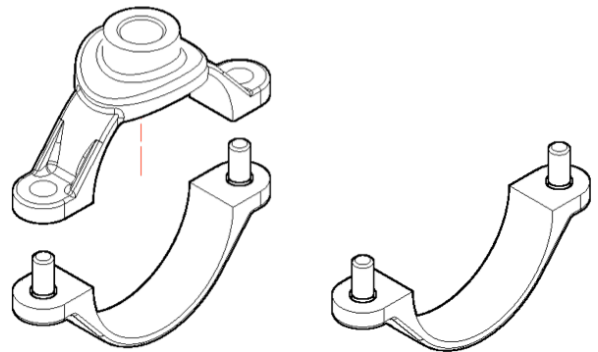

3. Hold bottom half underneath pipe. Ensure pipe area is clean, smooth and free from damage or defects.

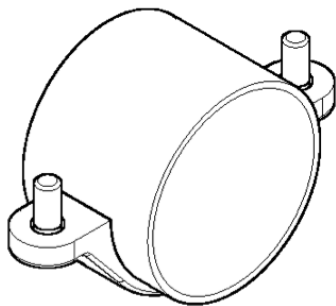

4. Place top half of Tapping Band over pipe. Locate bolt holes in top half into bolts in bottom half.

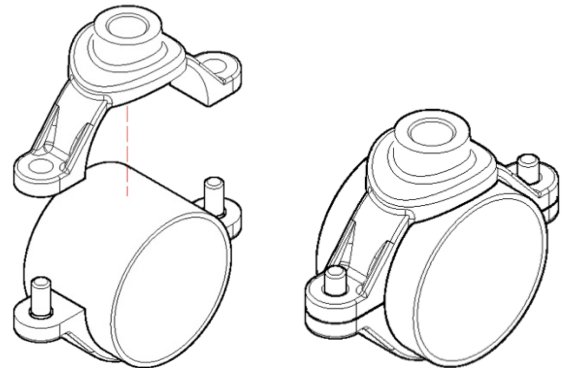

5. Make sure seal is correctly located in top half, with curved lip sealing on pipe.

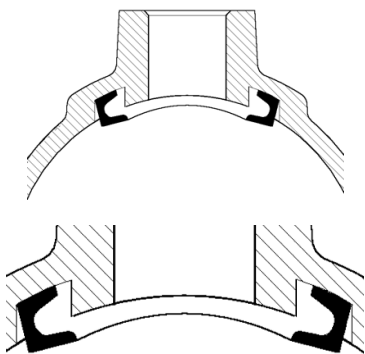

6. Tighten nuts evenly, maximum tightening torque 10-15nm. Take care not to damage or distort pipe.

